

# GMSW 6 PLUS VX

## MONOVALENT HEATING SYSTEM WITH BRINE AS HEAT SOURCE

ORDER NUMBER: 264801  
SERIES: GOLF MIDI PLUS  
TF MAX. 65 °C

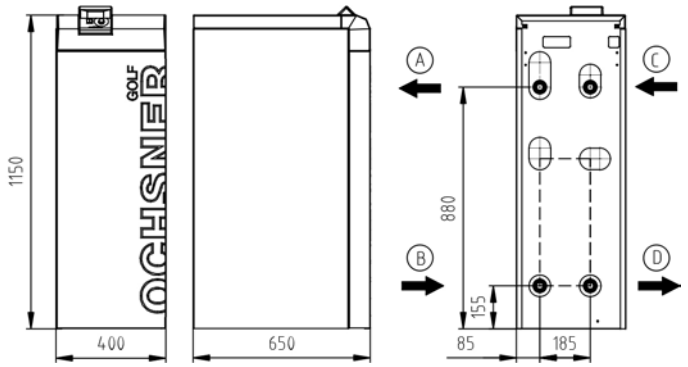

Ⓐ FLHC (outlet)    Ⓑ RTNHC (inlet)    Ⓒ WQA (inlet)    Ⓓ WQA (outlet)

### APPLIANCE DATA

Dimensions HxWxD	[mm]	1150x400x650
Hydraulic connection	[inch]	1 1/4"
Weight	[kg]	150
Casing colour		Tiger white 29/11289/grey RAL 7016

### SPECIFICATION

Phases/nominal voltage/frequency	[~]/[V]/[Hz]	1/230/50
Output factor cos φ		0,90
Fuse protection (tripping curve "C")	[A]	16
Max. operating current	[A]	12,80
Max. starting current/max. with soft start	[A]	60.00 / 30.00
Sound power level/sound pressure level (at 1 m distance)	[dBA]	43.00 / 35.00

### HEATING MODE PERFORMANCE FIGURES (to EN 14511)

#### Standard point B0/W35

Heating output	[kW]	5,80
Total power consumption / operating current	[kW]/[A]	1.20 / 5.80
COP		4,80

#### Operating point B0/W50

Heating output	[kW]	5,30
Total power consumption / operating current	[kW]/[A]	1.70 / 8.20
COP		3,10

#### Operating point B0/W60

Heating output	[kW]	5,00
Total power consumption / operating current	[kW]/[A]	2.00 / 9.70
COP		2,50

### CONDENSER

Type		Plate heat exchanger
Material		Stainless steel 1.4301
Max. refrigerant operating pressure	[bar]	45
Max. heat transfer medium operating pressure	[bar]	6
Heat transfer medium temperature differential	[K]	5
Application range	[°C]	65
Heat transfer medium		Water
Test pressure	[bar]	54
Heat transfer medium flow rate	[m³/h]	1,00
Internal pressure differential	[mbar]	70
Flow meter FM standard	external	FM-DN 20 kvs 10
Circulation pump heat sink (WNA)	Internal	Yonos Para RS 25/7.5
Residual head I WNA external, incl. FM	[mbar]	604

### REFRIGERANT CIRCUIT

Refrigerant		R410A
Refrigerant charge	[kg]	1,7

### COMPRESSOR

Type		Scroll
Output levels		1
Speed	[rpm]	2900
Voltage/frequency	[V]/[Hz]	230/50

### EVAPORATOR

Type		Plate heat exchanger
Material		Stainless steel 1.4401
Number	[pce]	1
Max. heat transfer medium operating pressure	[bar]	6
Max. refrigerant operating pressure	[bar]	12
Heat transfer medium temperature differential	[K]	3
Application range	[°C]	-5/+20
Heat transfer medium		Brine max. 30%
Test pressure	[bar]	54
Heat transfer medium flow rate	[m³/h]	1,45
Internal pressure differential	[mbar]	140
Flow meter (FM) standard	external	FM-DN 20 kvs 10
Circulation pump heat source (WQA)	Internal	Stratos Para 25/1-8
Residual head I WQA external, incl. FM	[mbar]	645

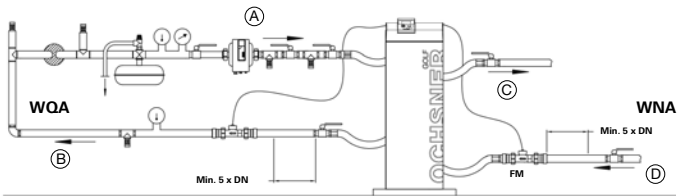

- (A) Heat source inlet
- (B) Heat source outlet
- (C) Heat pump flow
- (D) Heat pump return

### RECOMMENDED ACCESSORIES

Heat pump separating cylinders	min. PU300	30 l/kW at B0/W35
DHW tank	min. SP300/SP350	30 l/kW at B0/W50
3-way switching module	DN25 (1 1/4")	kvs 10, pressure loss 14 mbar
External PHE for DHW heating	PHE 2007	Prim.: 1" / 28 mbar Sec.: 1" / 32 mbar
Brine collector set for shallow laying	ESK 4	Pressure loss 86 mbar incl. brine distributor

### EXTRACTION CAPACITY ACC. TO VDI 4640

#### FOR SHALLOW LAYING

Soil conditions	Max. spec. extraction capacity at 1800 h/a	Max. spec. extraction capacity at 2400 h/a
Dry, non-cohesive soil	10 W/m <sup>2</sup>	8 W/m <sup>2</sup>
Cohesive soil, moist	25 W/m <sup>2</sup>	20 W/m <sup>2</sup>
Water-saturated soil with sand/gravel	40 W/m <sup>2</sup>	32 W/m <sup>2</sup>

#### FOR DEEP TRENCH LAYING

Soil conditions	Max. spec. extraction capacity at 1800 h/a
Cohesive soil, moist	100 W/m deep trench
Water-saturated soil	125 W/m deep trench

#### FOR GEOTHERMAL PROBES

Soil conditions	Spec. extraction capacity at 1800 h/a	Max. spec. extraction capacity at 2400 h/a
Dry sediment	25 W/m	20 W/m
Shale, slate	45 W/m	35 W/m
Firm rock with high thermal conductivity	84 W/m	70 W/m
Substratum with high groundwater flow	65-80 W/m	55-65 W/m

### SIZING RECOMMENDATION WITH BRINE AS HEAT SOURCE

Pressure loss in connection line, incl. individual losses	Max. 100 mbar
Pressure loss in brine circuits or probes, incl. brine distributor	Max. 300 mbar

### PERFORMANCE CURVES GMSW 6 PLUS VX

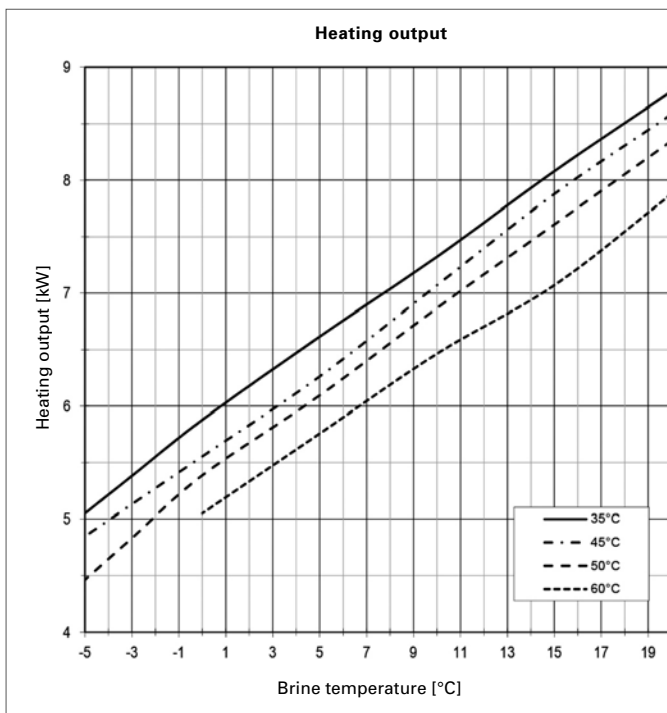

### PRODUCT DATA ErP: GMSW 6 PLUS VX

	COLDER	MEAN	HOTTER
<b>LOW TEMPERATURE</b>	<b>A++</b>		<b>35°C</b>
η <sub>s</sub>	208	199	195
Energy consumption	[kWh] 2656	2330	1536
P rated	[kW] 6	6	6
SCOP	5,40	5,16	5,06
<b>MEDIUM TEMPERATURE</b>	<b>A++</b>		<b>55°C</b>
η <sub>s</sub>	136	131	129
Energy consumption	[kWh] 3551	3087	2031
P rated	[kW] 5	5	5
SCOP	3,61	3,48	3,42
<b>DHW</b>	<b>A</b>		<b>SP300</b>
η <sub>WH</sub>	88	88	88
Energy consumption	[kWh] 1621	1621	1621
Draw-off profile	XL		
Tank losses	[W] 94		

	indoor	outdoor
Sound power level	[dBA] 43,0	-
Controller class with room remote control	VII	Controller contribution [%] 3,5
Controller class without room remote control	III	Controller contribution [%] 1,5

