

AIR 80 C22A

HIGH EFFICIENCY AIR/WATER HEAT PUMP
INCL. HORIZONTAL SPLIT EVAPORATOR

ORDER NUMBER: 288610
SERIES: M6
TF MAX. 65 °C
SPLIT

APPLIANCE DATA

Dimensions HxWxD	[mm]	1900x680x680
Hydraulic connection	[inch]	2"
Weight	[kg]	305
Casing colour		White/anthracite

HEATING MODE PERFORMANCE FIGURES (to EN 14511)

Standard point A10/W35

Heating output	[kW]	83,00
Total power consumption / operating current	[kW]/[A]	18.90 / 34.10
COP		4,40

Operating point A7/W35

Heating output	[kW]	75,60
Total power consumption / operating current	[kW]/[A]	18.90 / 33.30
COP		4,00

Standard point A2/W35

Heating output	[kW]	65,10
Total power consumption / operating current	[kW]/[A]	18.10 / 32.00
COP		3,60

Standard point L-7/W35

Heating output	[kW]	47,30
Total power consumption / operating current	[kW]/[A]	16.30 / 30.10
COP		2,90

Operating point L-10/W35

Heating output	[kW]	41,40
Total power consumption / operating current	[kW]/[A]	15.90 / 29.00
COP		2,60

Operating point A2/W50

Heating output	[kW]	57,30
Total power consumption / operating current	[kW]/[A]	20.90 / 38.20
COP		2,70

Operating point A2/W60

Heating output	[kW]	54,20
Total power consumption / operating current	[kW]/[A]	23.60 / 43.80
COP		2,30

COOLING MODE PERFORMANCE FIGURES

Operating point A30/W18

Cooling capacity	[kW]	66,80
Total power consumption / operating current	[kW]/[A]	20.90 / 33.60
Energy efficiency ratio EER		3,20

Operating point A30/W7

Cooling capacity	[kW]	61,70
Total power consumption / operating current	[kW]/[A]	20.60 / 33.50
Energy efficiency ratio EER		3,00

Hydraulic version			Electric immersion heater		3-way switching module	
			Internal	external	Internal	external
M2-1	M4-1		x		x	
M2-2	M4-2			x	x	
M2-3	M4-3		x			x
M2-4	M4-4	M6		x		x

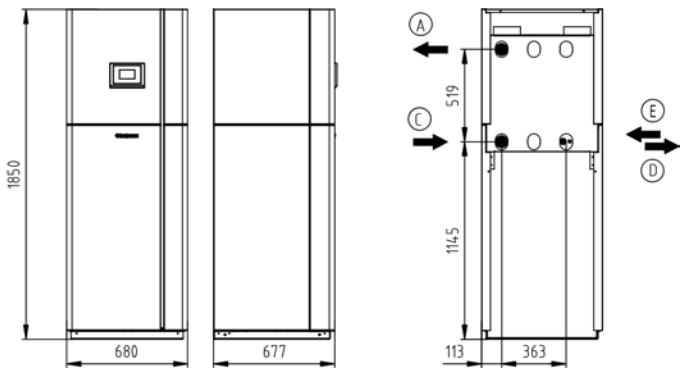

(A) FLHC (outlet) (B) FLT (outlet) (C) RTN (inlet) (D) WQA (outlet) (E) WQA (inlet)

SPECIFICATION

Phases/nominal voltage/frequency	[~]/[V]/[Hz]	3/400/50
Output factor cos φ		0,81
Fuse protection (tripping curve "C")	[A]	80
Max. operating current	[A]	69,60
Max. starting current/max. with soft start	[A]	248.00 / 124.00
Sound power/sound pressure level (at 1 m distance) indoor unit	[dBA]	60.00 / 52.00
Sound power/sound pressure level (at 10 m distance), outdoor unit	[dBA]	64.0 / 36.0

CONDENSER

Type		Plate heat exchanger
Material		Stainless steel 1.4301
Max. refrigerant operating pressure	[bar]	45
Max. heat transfer medium operating pressure	[bar]	10
Heat transfer medium temperature differential	[K]	5
Application range	[°C]	65
Heat transfer medium		Water
Test pressure	[bar]	59
Heat transfer medium flow rate	[m³/h]	13,00
Internal pressure differential	[mbar]	312
Flow meter (FM)	external	FM 50 x 2" (fem.), kvs 40
Circulation pump heat sink (WNA)	external	Stratos Para 65/1-12
Residual head I WNA external	[mbar]	618 (inkl. VMT)

REFRIGERANT CIRCUIT

Refrigerant		R410A
Defrost technology		Hot gas / reversal system
Refrigerant charge	[kg]	28,5

COMPRESSOR

Type		Scroll
Output levels		1
Speed	[rpm]	2900
Voltage/frequency	[V]/[Hz]	400/50

FAN

Type		Axial EC
Number	[pce]	2x2
Voltage/frequency	[V]/[Hz]	230/50
Power consumption	[W]	2 x 430
Max. operating current	[A]	2 x 2.80

EVAPORATOR

Unit type		VHS-M 80
Dimensions HxWxD	[mm]	1080x2220x960
Type		Finned tube
Number	[pce]	2
Weight	[kg]	180
Fin pack material		Copper/ aluminium
Casing material		Stainless steel (coated)
Max. refrigerant operating pressure	[bar]	45
Relative humidity	[%]	80
Heat transfer medium temperature differential	[K]	5,00
Air flow rate	[m³/h]	2x9800
Application range min./max	[°C]	-22 / 40



SPLIT EVAPORATOR VHS-M 80

RECOMMENDED ACCESSORIES

	Order no./type	Description	Pressure loss
Heat pump buffer tank	min. PU2000	30 l/kW at L2/W35	-
DHW tank	min. SP1000	30 l/kW at L2/W50	-
External plate heat exchanger (DHW911340 heating)	PHE 9610	Prim.: 2" Sec.: 2"	Prim.: 16 mbar Sec.: 69 mbar
3-way switching module internal	-	-	-
3-way switching module external	290342	DN50 (2"), kvs 40	106 mbar
Electric immersion heater internal	-	-	-
External electric immersion heater (heat pump buffer tank)	922509, 922508	3 x 9 kW + 1 x 6 kW	-

Application	Booster heater output
Bivalent parallel	Sizing according to calculated value (offer program), but with minimum 50% of building heat load
Bivalent partial parallel	Sizing to 100% of building heat load
Bivalent alternative	Sizing to 100% of building heat load

	Max. connection length	Max. height differential
AIR 80 C22A	L ≤ 15	Hmax ≤ 5

LIMITS OF USE AIR 80 C22A

Outdoor temperature/max. heat pump flow temperature	A-10/W65°C A-15/W60°C A-20/W55°C
Underfloor heating (-15°C / 35°C)	YES
Radiators (-15°C / 50°C)	YES
Radiators (-15°C / 55°C)	-
Radiators (-15°C / 65°C)	YES
Radiators (-15°C / 65°C)	Booster heater should be sized for 100% heat load
Domestic hot water	YES

PERFORMANCE CURVES AIR 80 C22A

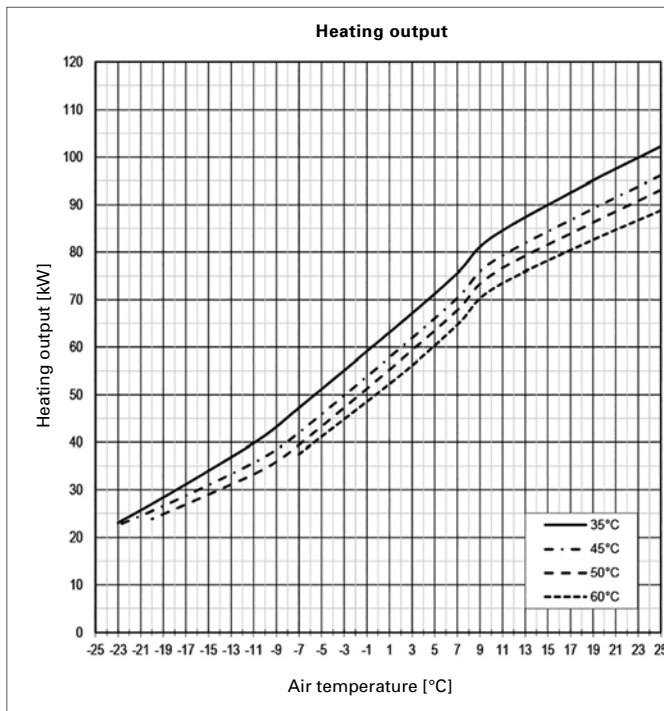

PRODUCT DATA **ErP: AIR 80 C22A**

		COLDER	MEAN	HOTTER
LOW TEMPERATURE	A+		35°C	
ηs		133	140	167
Energy consumption	[kWh]	37207	35111	19247
P rated	[kW]	51	61	61
SCOP		3,41	3,58	4,25
MEDIUM TEMPERATURE	A+		55°C	
ηs		106	113	136
Energy consumption	[kWh]	62205	48818	21450
P rated	[kW]	69	68	56
SCOP		2,73	2,90	3,47
		indoor	outdoor	
Sound power level	[dBA]	60,0	64	
Controller class with room remote control		VII	Controller contribution [%]	3,5
Controller class without room remote control		III	Controller contribution [%]	1,5

